

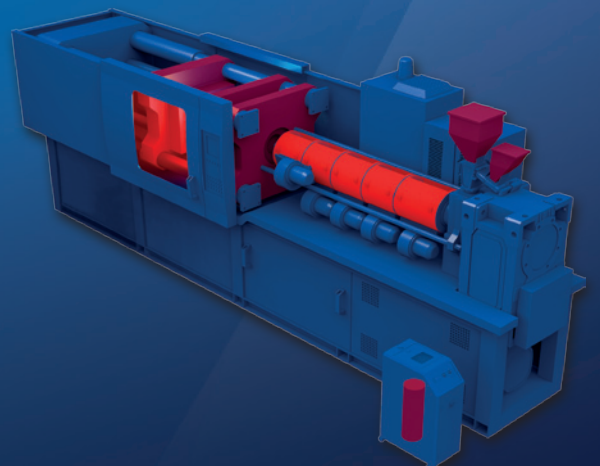

PLASTICS

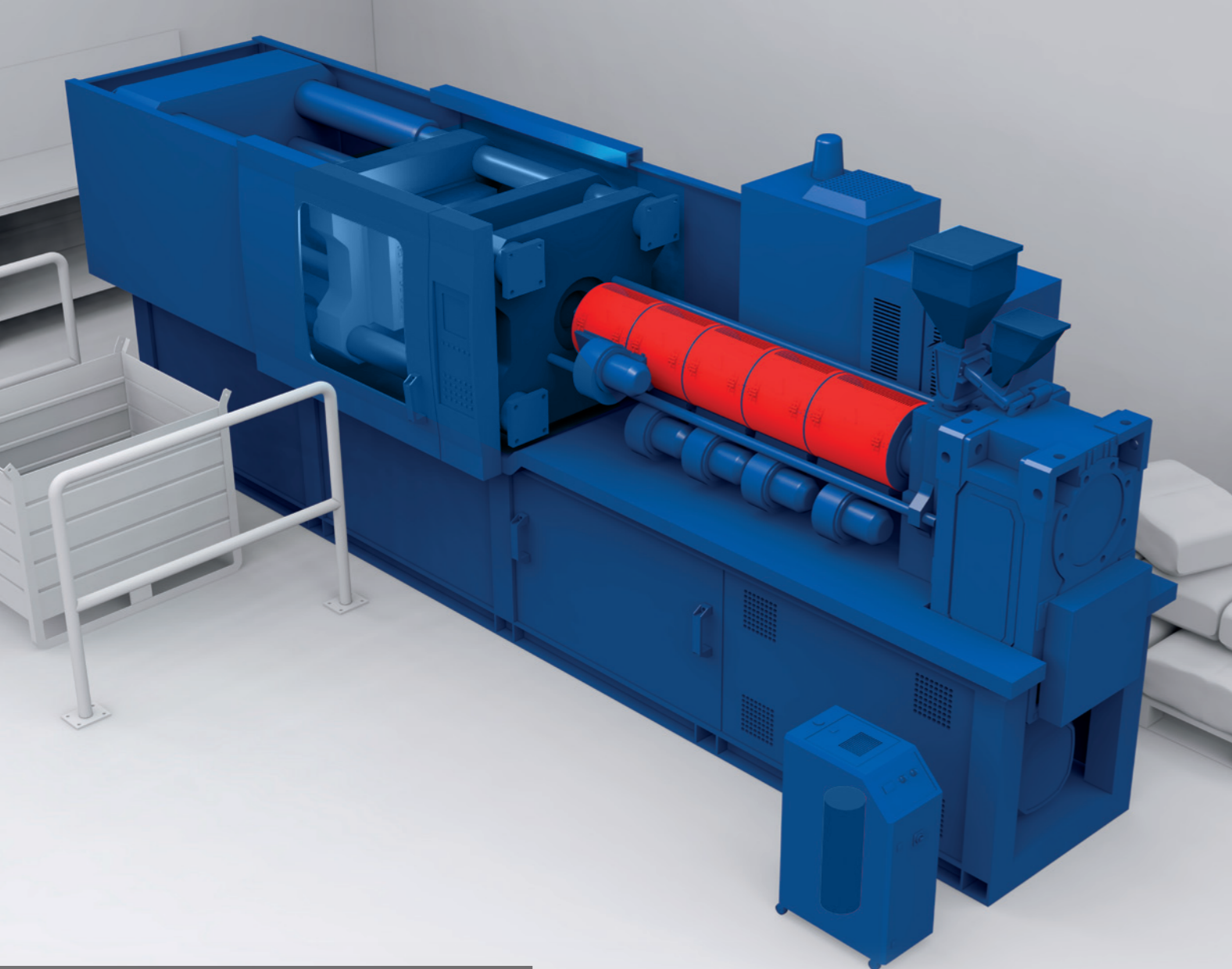



Zoppas Industries Heating Element Technologies meet plasticising cylinder heating needs with technical solutions which vary according to the specific requirements and customisations requested by the customer. The main types of electric heaters produced are the following:

1. Ceramic band heaters
2. Mica band heaters
3. Cast-in aluminium tubular heater for heating/cooling
4. Cartridges
5. Complete systems for heating and forced air cooling
6. Mica nozzle bands
7. MI nozzles

CYLINDER

CERAMIC BAND HEATERS

These heaters are made up of a spiral in NiCr 80/20 or FeCrAl alloy inserted in steatite modular elements, while the outer casing is made of sheet Alusi or, upon request, stainless steel. Thanks to the thermal transmission mode by irradiation, ceramic bands are the optimal heating solution for high power installations and can reach up to 450° C measured temperature on ceramic/cylinder contact surfaces.



The glass fibre insulation that wraps the ceramic mat has the dual function of limiting the temperature of the outer casing, and conveying the flow of heat to the surface to be heated. The power supply methodologies for the ceramic insulation bands are different depending on the specific needs required by the market: multipolar cable (for high temperatures), terminals, specific connectors, terminal pins etc. Our customisations can also affect processes (cuts, holes) and accessories (door sensors, signalling tags). Any additional insulating covers and or/safety function equipment can increase proven energy savings by 20%. Greater savings, up to 32%, can be achieved by external application of insulating fabric mats.

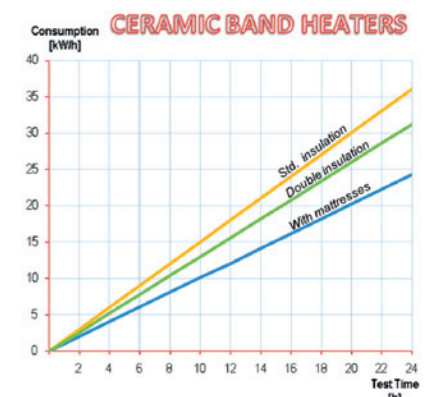

Main technical characteristics:

Mechanics

Diameter	Min. 50 mm
	Max. 550 mm (for diameters over 550 mm executions by sector are expected)
Width	Min. 30 mm
	Max. related to the diameter required

Electrics

Voltage	From 12 to 500 V (three-phase power supply possible through provision of star or triangle connectors)
Power	Specific loads up to 7 W/cm ² to decrease with increase of the nominal power installed. Standard tolerance according to VDE standard +5% -10%
Ampere Phase	Up to 40 A power according to the different types of connections

MICA BAND HEATERS



Consisting of an NiCr plate wrapped and insulated from appropriate supports in mica. The outer casing, usually made of sheet Alusi, is also made of stainless steel on request.

Compared to ceramic band heaters, those with mica insulation work by conduction, maximising their efficiency and reliability at temperatures up to 350° C, measured on mica/cylinder contact surfaces and with specific loads up to 4W/cm². The manufacturing technology with which they are produced and the quality of the materials used make these heaters particularly easy to assemble on the cylinder, without necessarily having to fit them, and fast at achieving required temperatures thanks to low thermal inertia. Power supply type (multipolar cable, terminals, connectors, terminal pins etc.), forms, works and accessories (such as door sensors, signalling tags, counter plates etc.) are all customisable elements, according to specific requirements of the customer.

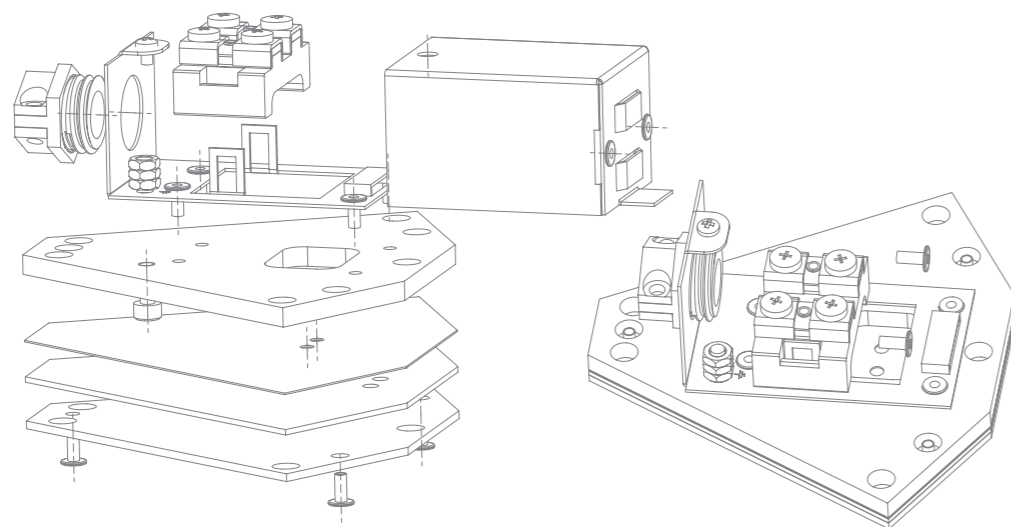

CAST-IN ALUMINIUM TUBULAR HEATER FOR HEATING/COOLING



It is the tubular electric heaters that, suitably shaped and immersed in cast aluminium alloy, ensure high standards of reliability, uniformity of surface temperature and long life. They are virtually problem-free with regard to electrical insulation due to bleeding in the processes of plastic injection or extrusion.

The most commonly used form is cylindrical and made in two halves, but can also be made flat. Achievable working temperatures stand at around 400° C, while the specific power reaches up to 6W/cm². The most suitable use for these elements is cylinder heating in the extruders, in that they can also be made with a system of cooling fins for quick cooling via a forced-air system. You can also integrate a coil to these products for coolant circulation. Also purely cooling castings are made.

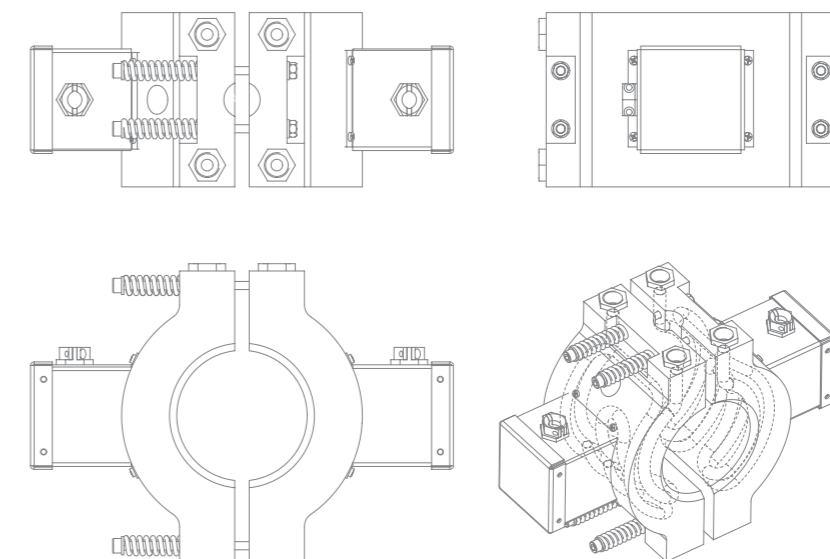

CARTRIDGES

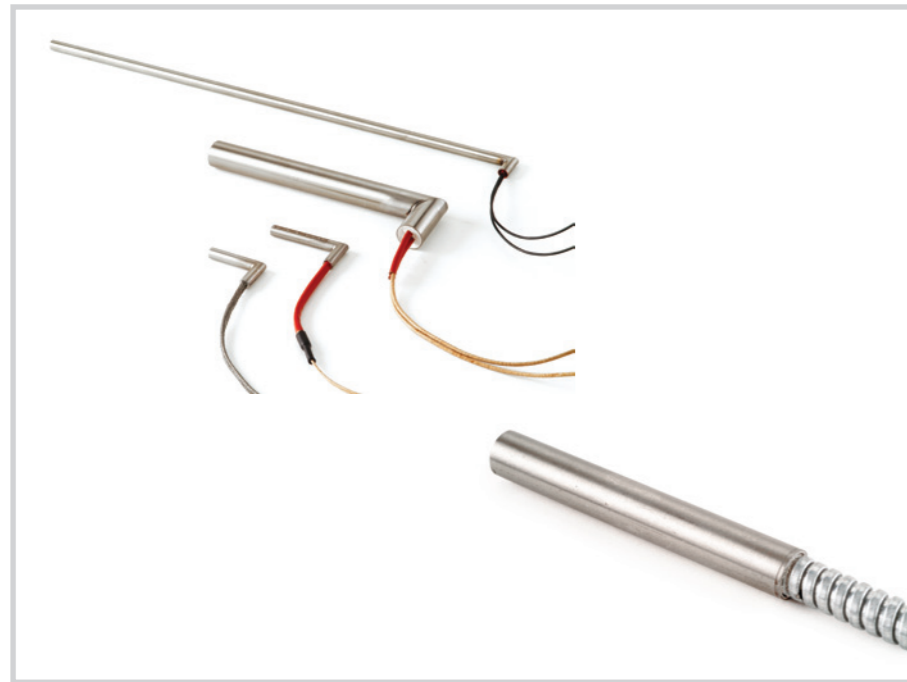

Known as Ultrawatt, high density cartridges are characterised by extreme versatility and precision of the thermal profile combined with high performance. In that they can reach temperatures up to 750° C or specific loads in the order of 40 W/cm².

The most common construction is with a straight, or 90° exit, and metal sheath to protect the cables at high temperatures. The sheath material used is mainly AISI 321, but, on specific customer request or according to particular temperature regimes, other steel alloys are also used. They are further customisable with integrated thermocouples, fittings, flanges etc.



Main technical characteristics:

Diameter		Diameter tolerance	Length tolerance	Temperature	Power tolerance
mm	inches				
6		-0.03	±2%	750	+5 -10%
6.25					
6.35	(1/4")				
6.5					
8					
9.5	(3/8")				
10					
12					
12.5					
12.7	(1/2")				
13					
15.9	(5/8")				
16					
19	(3/4")				
20					

Given the specific powers and high temperatures, it is necessary to drill holes bored with an idea tolerance of H7.

COMPLETE SYSTEMS FOR HEATING AND FORCED AIR COOLING

The major application sector for these systems is that of extrusion, in particular in the processing of PVC. The advantage of this assembly is a precise and uniform heating of bolted materials thanks to the combination of heating elements and elements for the dissipation of excess heat.

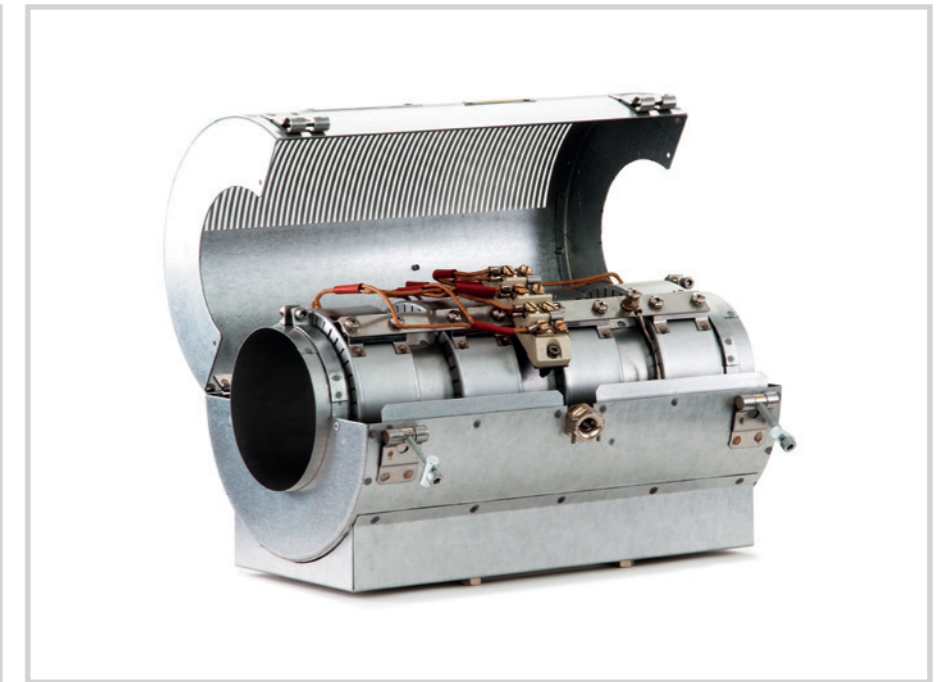

Depending on the performance required in these systems the heating function is entrusted to bandeau modular elements (both ceramic and mica) or cast-in aluminium heaters. The cooling process, however, takes place using forced and directed air which invests the resistance and heat sinks, which are usually made of aluminium or copper. To increase thermal efficiency and reduce the temperature on external surfaces, in accordance with accident-prevention regulations, the interior of these systems can be insulated with fully ecological fibreglass. This solution, including also the use of reflective materials within the structure, guarantees an energy saving increase. The cover plates can be made of various steel alloys, according to technical/aesthetic requirements, as dictated by the customer.

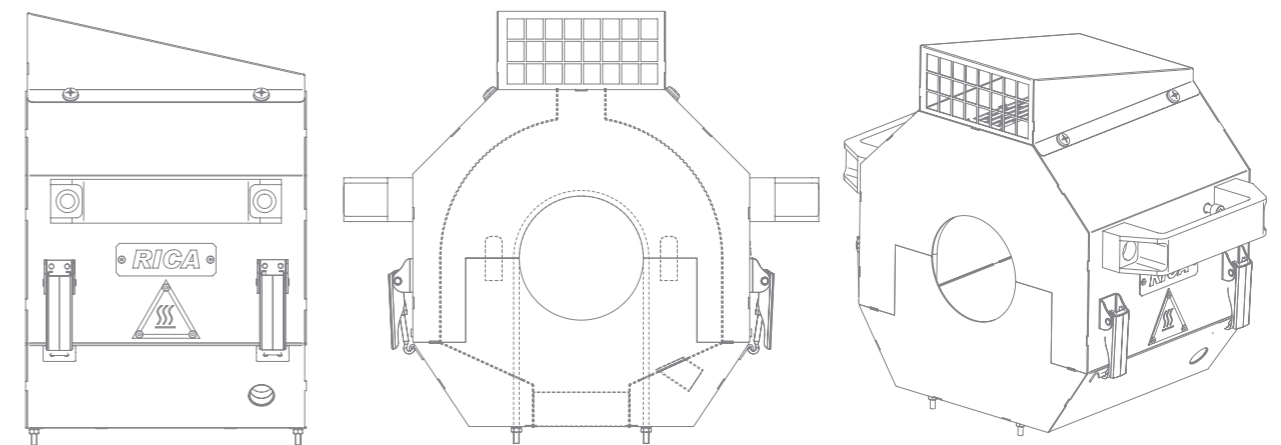

MICA NOZZLE BANDS



These are special mica bands made of stainless steel. The firmly welded cover with which they are equipped makes them particularly well suited to heating the press nozzles, ensuring their protection against pollution by material; typical problems of the injection head.

Operating limit temperature is 350° C standard, with specific loads of around 6W/cm². On request and under certain working conditions, versions can be made for higher temperatures, up to a ceiling of 450° C. Customisations can also include the use of integrated thermocouples and accessories such as door sensors and connectors. Power is supplied using a special cable which is armoured against high temperatures and equipped with an Earth wire.

Available exit types:

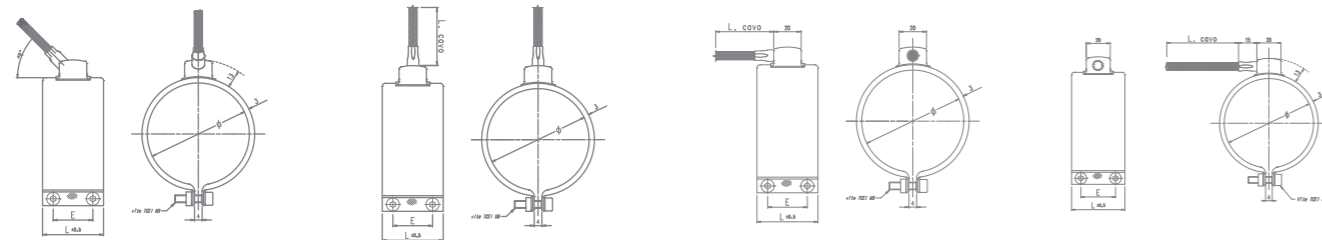

45° Axial cable exit

Radial cable exit

Axial cable exit

Tangential cable exit

MI NOZZLES

In comparison to traditional mica nozzle bands, the MI bands use an Al₂O₃ aluminium support, which is characterised by an increased thermal conductivity, with specified loads up to 12W/cm² and working temperatures of 600°C.



To allow increased working temperatures, these nozzles have special power cables, with mica insulation, while the steel frame with welded-on cover allows installations which are resistant to pollution from plastic materials. For these reasons they are suitable for use in PEEK and Teflon plastics materials injection types, and in applications that require fast nozzle heating and high system reliability.



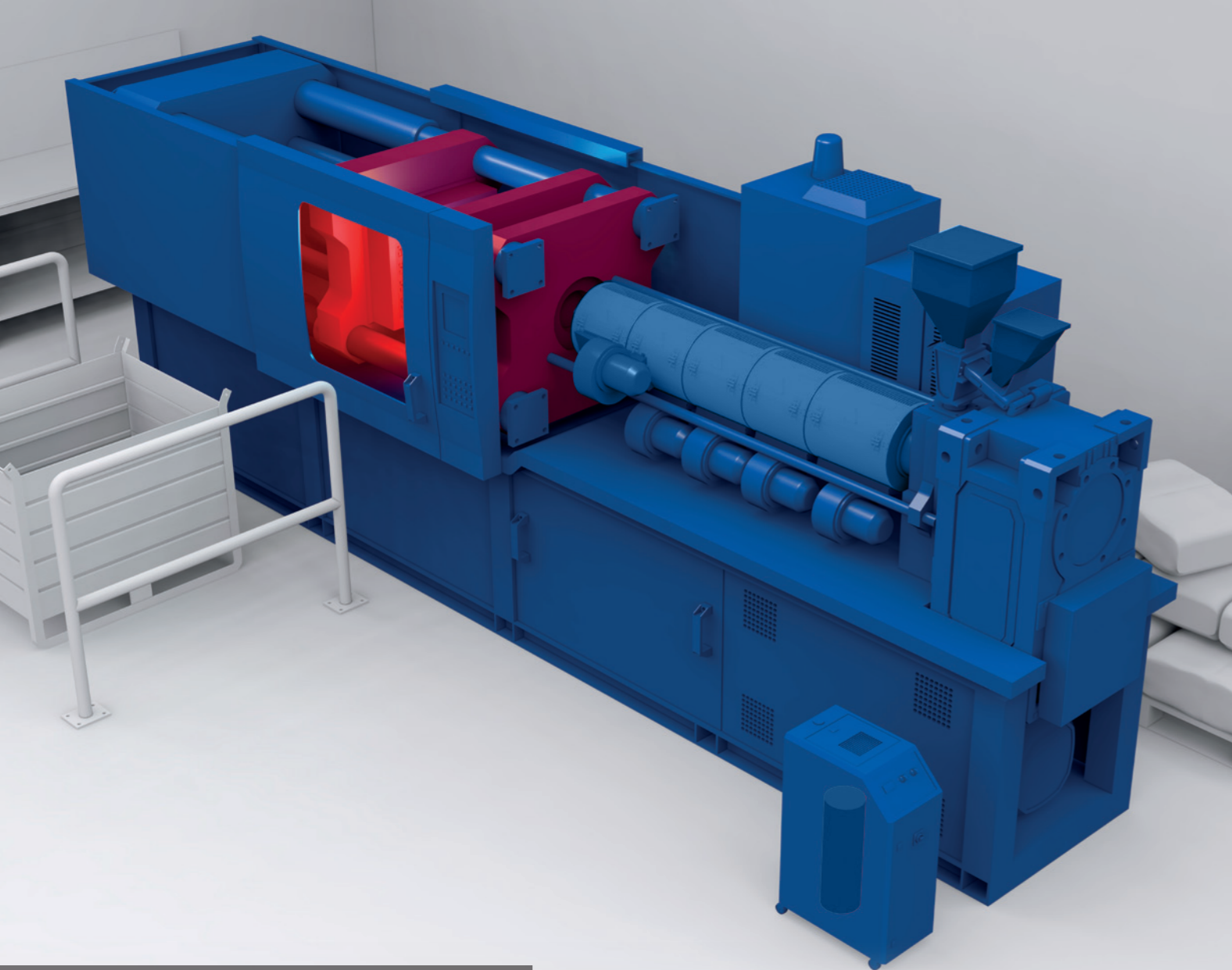

Zoppas Industries Heating Element Technologies, through the use of continually innovative construction technologies, also offer heating solutions for the mould, hot runner and manifold fields, and productions customised according to market and customer requirements.

The main types of electric heaters produced are the following:

1. Bands for reduced footprint nozzle
2. Cartridges
3. Microtube
4. Tubular heating elements

MOULD HOT RUNNER MANIFOLD

BANDS FOR REDUCED-FOOTPRINT NOZZLE

These are mica bands, generally made of sheet Alusi, and protected with a steel belt guard, the wires of which exit axially from the heater thickness. Their small size allows these bands to be ideally suited to moulds and hot runners. Maximum operating temperature proven at 350° C, with specific loads of around 6W/cm². Power is supplied using two single-pole cables which are armoured against high temperatures.



The construction standard is shown in this drawing:

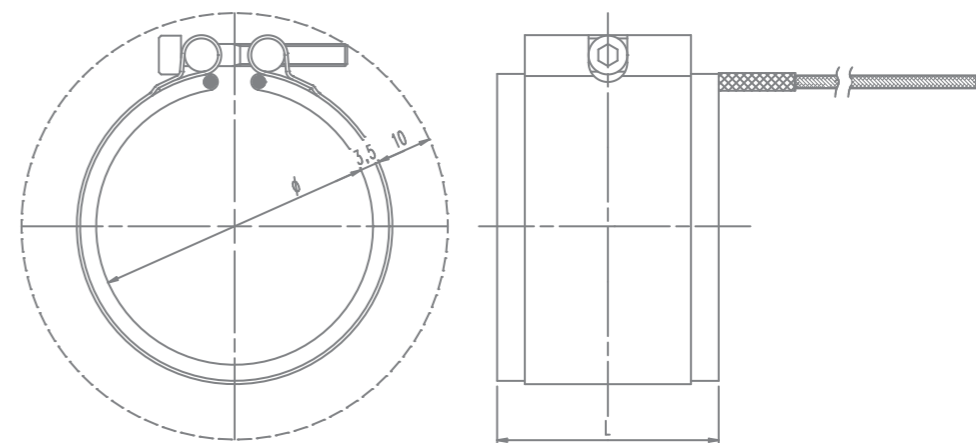

CARTRIDGES



High density cartridges, known as Ultrawatt, are characterised by extreme versatility and precision of the thermal profile combined with high performance. In that they can reach temperatures of around 750° C or specific loads in the order of 40 W/cm². Thanks to these features the cartridges are widely used in mould heating or flat extrusion heads.

CARTRIDGES

Uses multiple cartridge heaters connected in series of greatest cartridge resistance, when addressing specific dimensional needs such as being unable to employ additional power cables or temperature control sensors. The uniqueness of this solution is that, in order to maintain heating accuracy with a single control thermocouple, these resistors have a very narrow power tolerance compared to standard resistors.



The most common types are constructed using internal cable connection, with or without ceramic hoods, and external connections to benefit from their entire lengths being used as heat emitters. The sheath material used is mainly AISI 321, but, on specific customer request or according to particular temperature regimes, installations with other steel alloys are also available.

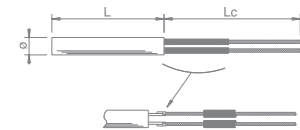

Type H external connection
Cartridge heater with external connections, insulated with fibreglass silicone sheaths between the rigid nickel manganese terminals and flexible cables.

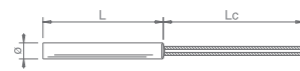

Type X internal connection
Cartridge heater with fully flexible nickel power cables, insulated with Teflon, fibreglass and silicone.



Type S with ceramic isolator
Cartridge heater with internal connections with a ceramic insulator. The ceramic insulator (Lp in the figure) footprint is a maximum of 10 mm.

The main technical characteristics are summarised in the following table:

Diameter		Tolerance diameter	Tolerance width	Temperature	Tolerance power
mm	inches				
6		-0.03	±2%	750	+5 -10%
6.25					
6.35	(1/4")				
6.5					
8					
9.5	(3/8")				
10					
12					
12.5					
12.7	(1/2")				
13					
15.9	(5/8")				
16					
19	(3/4")				
20					

Given the specific powers and high temperatures, it is necessary to drill holes bored with an ideal tolerance of H7.

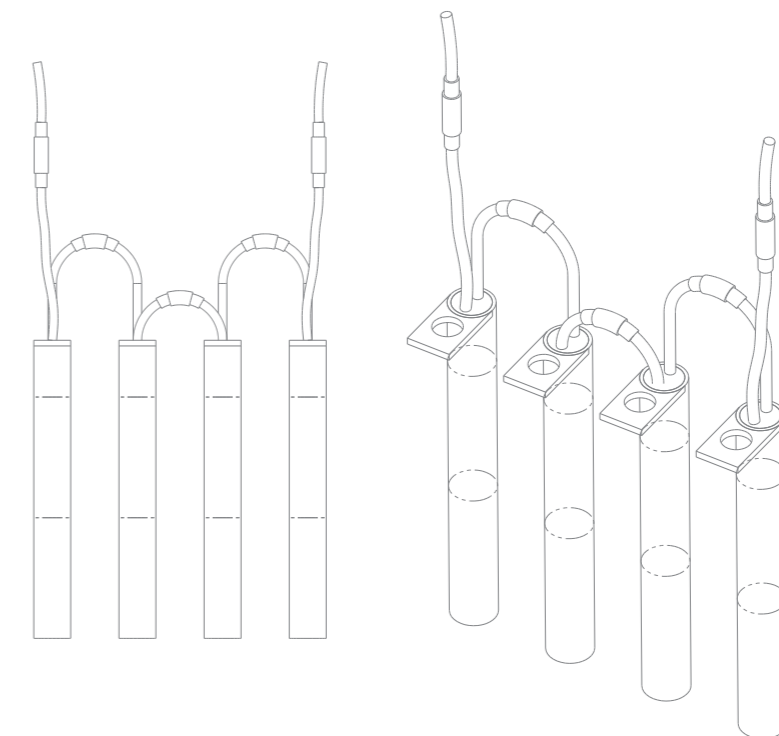

MICROTUBULAR HEATERS



They are heaters made up of a metallic steel sheath containing a resistive NiCr 80/20 filament, insulated with high purity compacted magnesium oxide. This structure ensures durable high performance, power density and operating temperature. Thanks to these characteristics and reduced overall dimensions they are particularly suitable for heating of hot runner nozzles.

Form customisations are possible (straight or coiled) and those of isolated Thermocouple type ("J", Fe CuNi, or "K", NiCr Ni). To ensure good electrical insulation, sealing is carried out using silicone or glass. The power cables, in PTFE nickel, can be protected by a fibreglass silicone or braided metal sheath. Versions are also available with a simple-closure carter, with strong sealing screws and with carter welded on to the microtube.

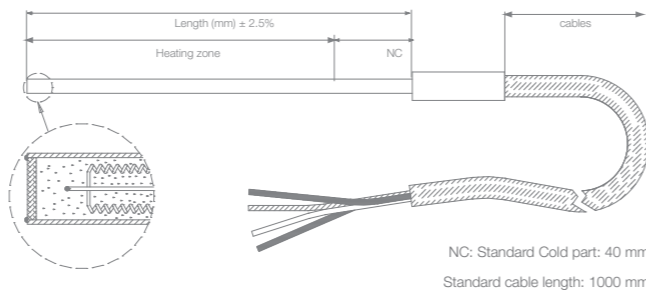

Available sections and technical characteristics:

Sections	Ø 1.8	Ø 3.1	Ø 4	4 x 2.5	3.2 x 1.8	3.2 x 3.2	2.4 x 1.4
Sheath	Aisi 304	Aisi 304	Aisi 304	Aisi 304	Aisi 304	Aisi 304	Aisi 304
Thermocouple	No	No	Yes/No	Yes/No	No	Yes/No	No
Minimum bending radius	2 mm	5 mm	6 mm	5 mm side 4 4 mm side 2.5	5 mm side 3.2 4 mm side 1.8	5 mm	5 mm side 2.4 4 mm side 1.4
Maximum length (straight)	1200 mm	1800 mm	2500 mm	2500 mm	1800 mm	2500 mm	1800 mm
Length tolerance	± 2,5%	± 2,5%	± 2,5%	± 2,5%	± 2,5%	± 2,5%	± 2,5%
Power Tolerance	± 10%	± 10%	± 10%	± 10%	± 10%	± 10%	± 10%
Input voltage	24V-240 V	24V-240 V	24V-240 V	24V-240 V	24V-240 V	24V-240 V	24V-240 V
W/Cm ² max	8	8	8	8	8	10	8
Insulation	5M Ω	5M Ω	5M Ω	5M Ω	5M Ω	5M Ω	5M Ω
Dielectric Strenght	800 V	800 V	800 V	800 V	800 V	800 V	800 V
Maximum Amp.	3 A	5 A	5 A	5 A	5 A	5 A	5 A
Operating temperature	550° C	550° C	550° C	550° C	550° C	550° C	550° C

The models are available straight or coiled (with joined or differentiated coils), according to the Customer's wishes.

TUBULAR HEATING ELEMENTS

These electric heaters consist of a spiral of NiCr 80/20 resistive wire, insulated with compressed magnesium oxide and protected on the outside by a metal sheath in stainless steel or nickel.

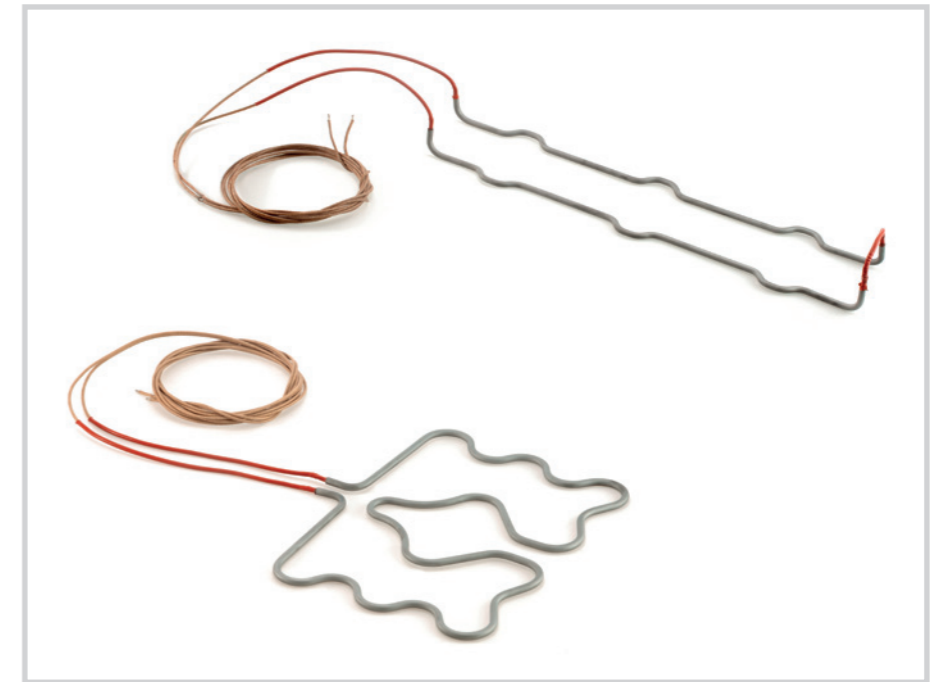

Widely used for heating of moulds, hot runners and manifolds, the tubular heating elements allow specific loads of 7W/cm² and temperatures of around 760°C, whilst still providing reduced dimensions, increased reliability, durability and uniformity of surface temperature. According to specific customer requirements, they can also be made both straight or suitably shaped.

Summary table of available materials, diameters, and connections:

The following table summarises the available diameters, materials, and connections:

Circular section	Sheath materials	Connections
Available sections (mm)	AISI 304 - AISI 321 - AISI 309 - Nickel	Cables in Ni Teflon F.V. (temp Max 320°C) M4, M5 plates
Ø 6.25 - 6.5 - 8.5 - 10 - 12.5		

Given the extreme flexibility of shape it is important to take into account the following bend radius

Minimum bending radius			
Ø 6.25 - 6.5 13 mm	Ø 8.5 14.5 mm	Ø 10 18.5 mm	Ø 12.5 22.5 mm



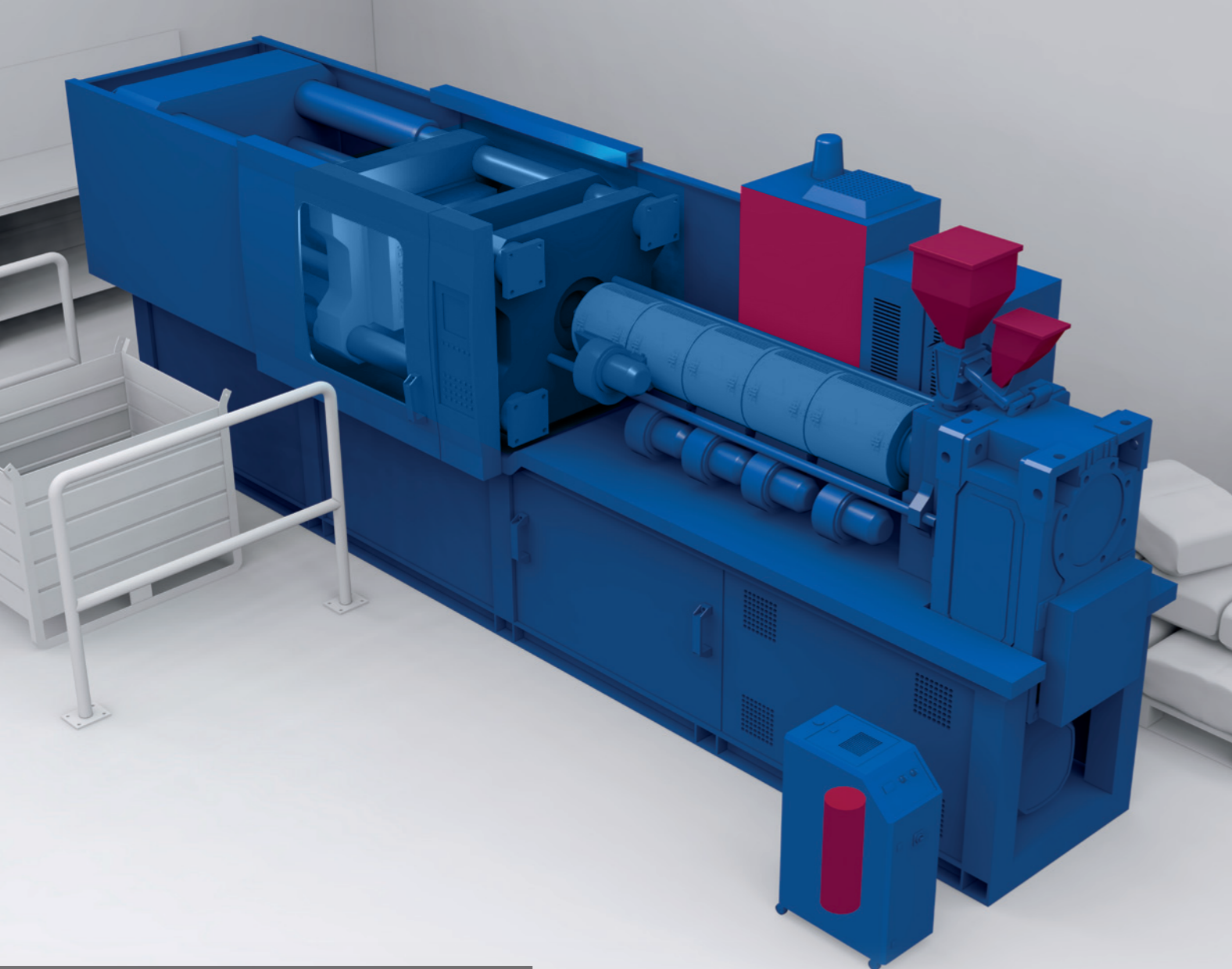

Zoppas Industries Heating Element Technologies meet auxiliary area heating needs, with a series of products which adapt best to specific requirements and customisations requested by the customer. The following types of electric heaters may essentially be proposed:

1. Tubular heaters on flange
2. Cartridge heaters
3. Etched Foil
4. Duct heaters with smooth and finned elements
5. Air heaters

DRYER CONTROL PANEL THERMOREGULATORS

TUBULAR HEATERS ON FLANGE

These are primarily used for de-humidification or drying of polymer grains and for heating water or oil in the temperature registers. They are made primarily with smooth tubular elements, brazed or welded on flanges in stainless steel of different sizes and shapes depending on the customer's requirements. They are equipped with a sump for the use of a control thermostat.



The available electrical connections are:

- Faston
- Nutplates
- Threaded connectors
- Cables
- Bridges

These are fixed to the terminal pins using electrical welds.

If however the pins are threaded, they are affixed using nuts tightened onto the pins themselves.

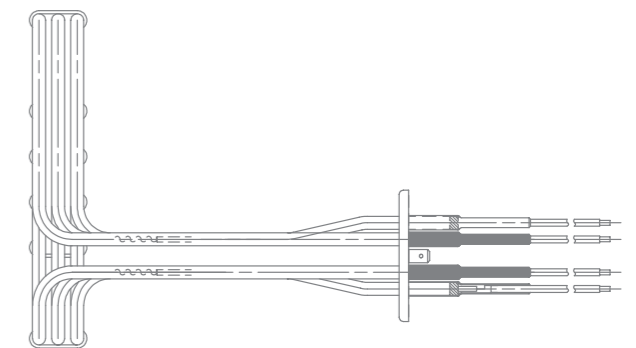
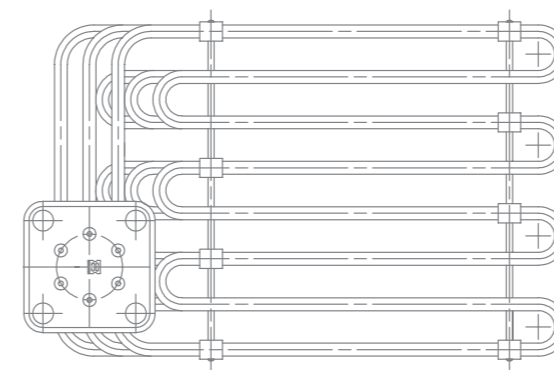

CARTRIDGE HEATERS



PTC self-regulating cartridges are used in conjunction with a aluminium finned heatsink inside electrical panels in order to prevent the formation of condensation.

ETCHED FOIL

The flexible foil heating elements in silicone are applied using double-sided adhesive, with which they are equipped, to the internal walls of cabinets and electrical boards, in order to avoid the formation of condensation.

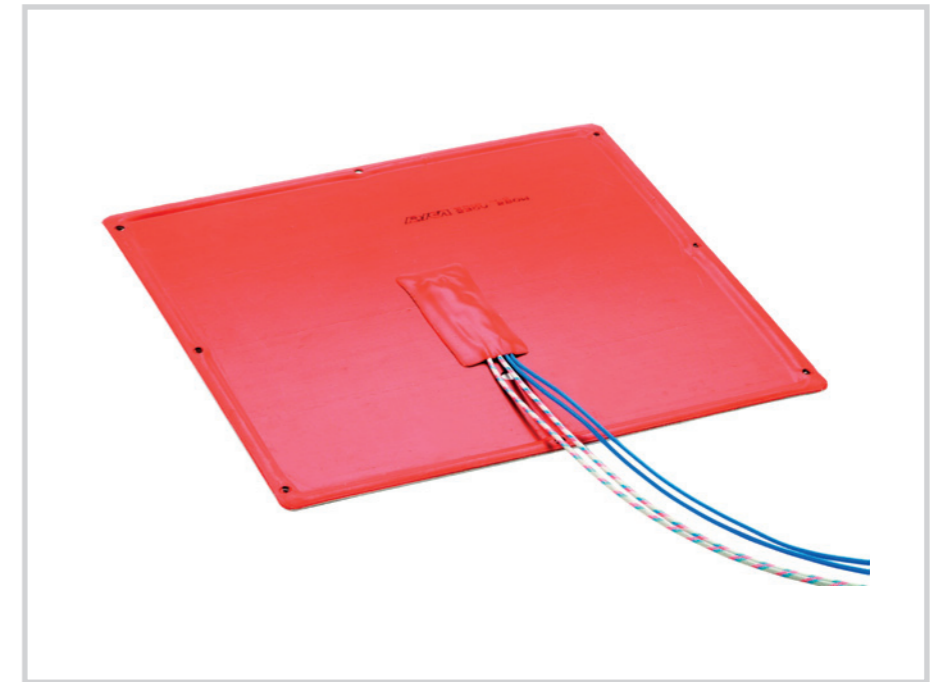

The anti-condensation heater has been developed to maintain a constant temperature inside closets, cabinets and enclosures for electrical equipment, in order to remove condensate that can cause corrosion of metal parts, or electric shock. The security aspect is down to the fact that the dispenser does not exceed a temperature of 60° C, therefore it is very suitable for plastic containers, and that the black anodizing gives it dielectric characteristics. The profile has been designed particularly to generate an excellent flow of convection, for minimal disturbance on walls and for easy installation.

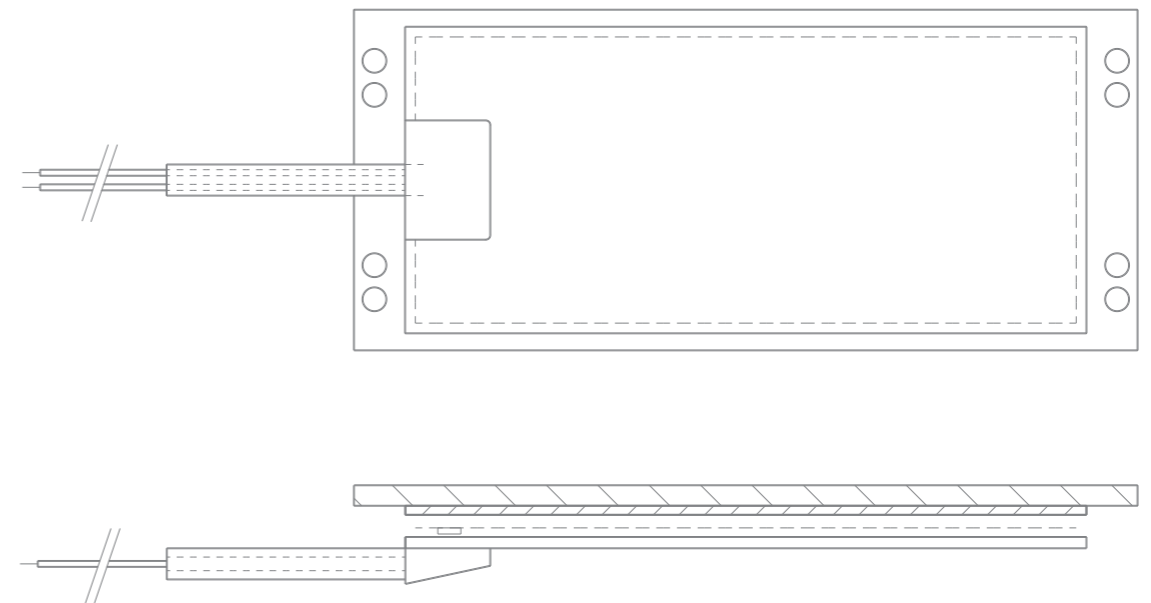
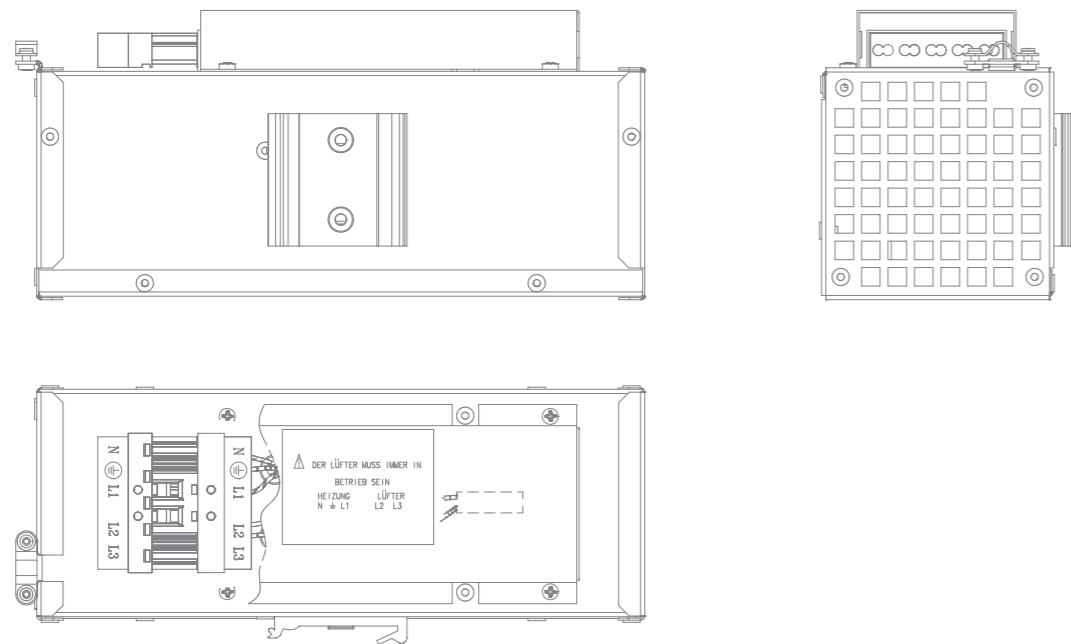

DUCT HEATERS WITH SMOOTH AND FINNED ELEMENTS



Electric duct heaters are used for drying and/or dehumidifying granular plastic material and are divided into two families:

- With smooth elements
- With finned elements

With smooth elements:

They are designed to ensure low pressure loss, have stainless steel structure and use individually replaceable straight tubular elements made of AISI 321. They work at a maximum operating temperature of 250° - 300°C. They are available with thermostatic trap for thermostats and electrical connections made with brass rods and M6-M8 screws for phase outlet. Thanks to their ease of assembly and compactness you can install modular power up to 108 kW and above.

With finned elements:

These are made with the finned solution that improves heat exchange in a reduced space. They have a stainless steel structure and use individually replaceable finned tubular elements made of AISI 321. They work at a maximum operating temperature of 250° - 300°C. They are available with thermostatic trap for thermostats and electrical connections made with brass rods and M6-M8 screws for phase outlet. Thanks to their ease of assembly and compactness you can install modular power up to 108 kW and above.

AIR HEATERS

They are used for dehumidification or drying of plastic polymers before processing. The main characteristic of these products is their remarkable compactness and versatility, as they can be connected to tubing using the threaded fittings at the ends where these are present.

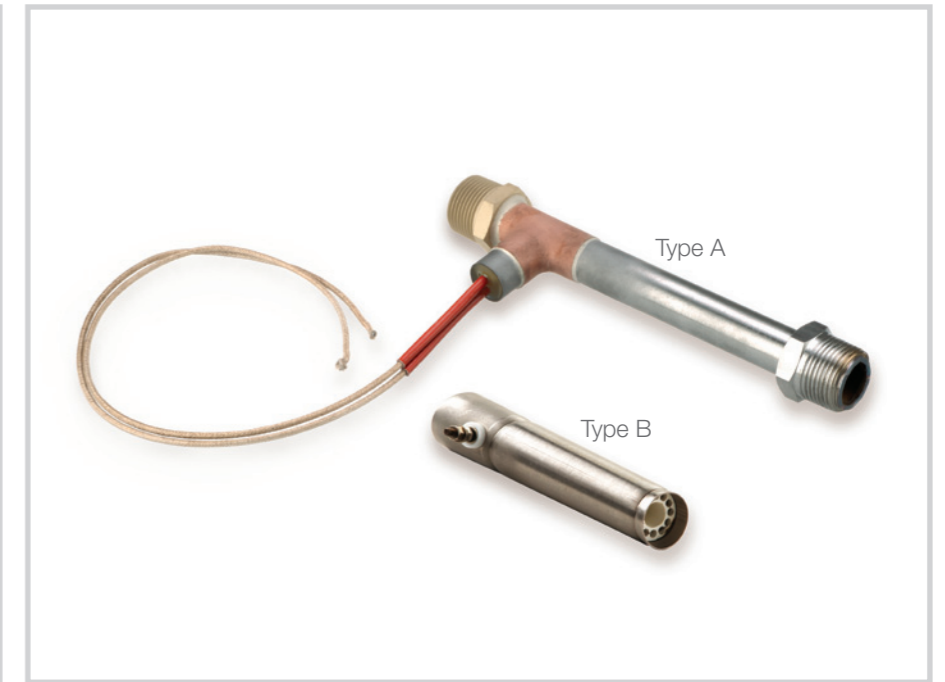

The heater allows the passage of air that flows through the body of the unit directly on to the resistive coils so that the air is warmed in the most efficient form.

Depending on the flow rate and air temperature they can reach loads specifically suited to the application and to efficient thermal exchange. They come in two types, A and B, as shown below. They can be equipped with a thermocouple on request.

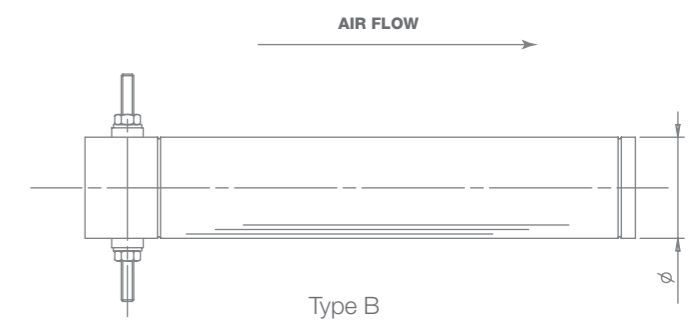
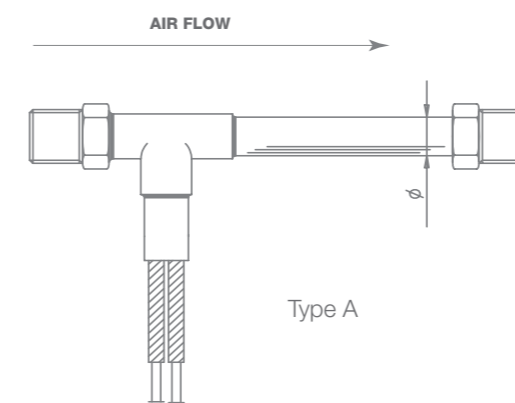



Zoppas Industries
Heating Element Technologies

RICA - Via Podgora, 26 - 31029 Vittorio Veneto (TV) - Italy
Tel. +39 0438 9101 - Fax +39 0438 912272 - 912236
www.zoppasindustries.com - rica@zoppas.com